



WINTER – 19 EXAMINATION

Subject Name: Fluid Mechanics & Machinery Model Answer

Subject Code:

22445

**Important Instructions to examiners:**

- 1) The answers should be examined by key words and not as word-to-word as given in the model answer scheme.
- 2) The model answer and the answer written by candidate may vary but the examiner may try to assess the understanding level of the candidate.
- 3) The language errors such as grammatical, spelling errors should not be given more Importance (Not applicable for subject English and Communication Skills).
- 4) While assessing figures, examiner may give credit for principal components indicated in the figure. The figures drawn by candidate and model answer may vary. The examiner may give credit for any equivalent figure drawn.
- 5) Credits may be given step wise for numerical problems. In some cases, the assumed constant values may vary and there may be some difference in the candidate's answers and model answer.
- 6) In case of some questions credit may be given by judgement on part of examiner of relevant answer based on candidate's understanding.
- 7) For programming language papers, credit may be given to any other program based on equivalent concept.

| Q. No. | Sub. Q. No. | Answer  | Marking Scheme     |
|--------|-------------|---|--------------------|
| 1.     |             | <b>Attempt any <u>FIVE</u> of the following:</b>  | <b>10 Marks</b>    |
|        | a)          | <b>Compare water and oil of specific gravity 0.8 on the basis of density &amp; viscosity.</b>   |                    |
|        | <b>Ans</b>  | Soil = $(\text{Density})_{\text{oil}} / (\text{Density})_{\text{water}}$<br>$0.8 = (\text{Density})_{\text{oil}} / 1000$<br>$(\text{Density})_{\text{oil}} = 800 \text{ kg/ m}^3$<br><br><b>Here it is not possible to find out viscosity</b> | 02 Marks           |
|        | b)          | <b>The pressure in the tyres of the four wheeler was measured as 33. State the unit of pressure in this case. Name the device use to measure this pressure.</b>   |                    |
|        | <b>Ans</b>  | The unit of pressure 33 in this case is PSI (Pound per square Inch).<br>The name of device used to measure is Bourdon Tube Pressure Gauge   | 01 Mark<br>01 Mark |
|        | c)          | <b>Show the difference between hydraulic gradient line &amp; total energy line with the help of suitable diagram.</b>   |                    |

|            |  |  |
|------------|--|--|
| <p>Ans</p> |  | <p>02 Marks</p>                                      |
| <p>d)</p>  | <p>Write Chezy's equation for frictional losses and list all the terms involved in it.</p>   |  |
| <p>Ans</p> | $V=C\sqrt{mi}$ <p>Where; V = velocity of water in pipe,<br/>m = hydraulic mean depth = A/P = d/4<br/>I = loss of head per unit length,<br/>C = Chezy's constant</p>  | <p>01 Mark<br/><br/>01 Mark</p>                      |
| <p>e)</p>  | <p>State the need of surge tank in hydroelectric power plant.</p>  |  |
| <p>Ans</p> | <ul style="list-style-type: none"> <li>• It is the tank provided in the path of penstock to avoid pulsating discharge at inlet of turbines.</li> <li>• To reduce effect of water hammer surge tanks are provided.</li> <li>• During flow of water from reservoir to turbine through penstock pressure surges are created to compensate these surges surge tank is provided.</li> </ul> | <p>01 Mark for each point<br/><br/>(any 2 point)</p> |
| <p>f)</p>  | <p>State the difference between Static head &amp; Manometric head in centrifugal pump.</p>   |  |
| <p>Ans</p> | <p><b>Static head:</b> The sum of suction head &amp; delivery head is known as static head.<br/><b>Manometric head:</b> It is the total head that pump is required to develop. This include all losses. This is equal to difference between pressure head at inlet &amp; outlet of pump.</p>   | <p>01 Mark<br/><br/>01 Mark</p>                      |
| <p>g)</p>  | <p>Draw indicator diagram for reciprocating pump showing the effect of accelerating head and frictional head.</p>  |  |
| <p>Ans</p> |  | <p>02 Mark</p>                                       |

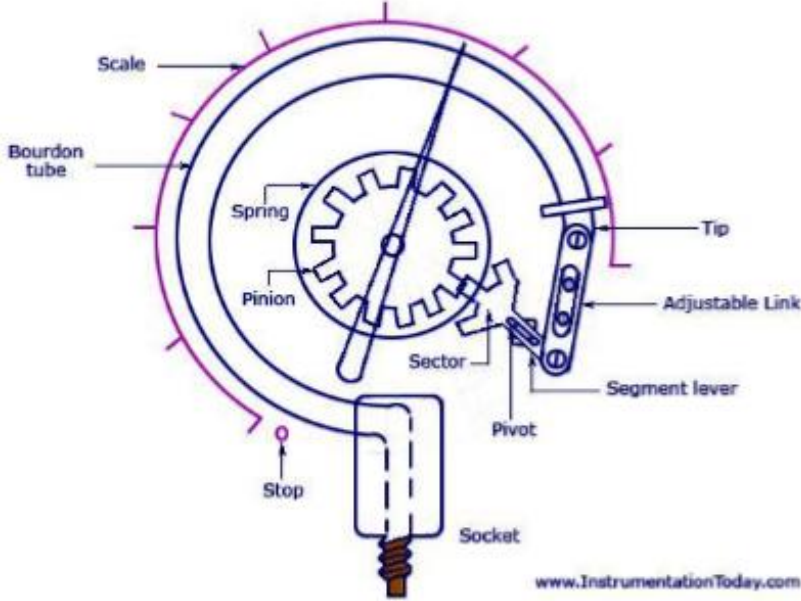
|     |  |  |
|-----|--|--|
| Q.2 | Attempt any <b>THREE</b> of the following:   | 12 Marks   |
| a)  | Draw sketch of Bourdon tube pressure gauge and state its advantages.   |  |
| Ans |  <p style="text-align: center;"><b>Bourdon Tube Pressure Gauge</b></p> <p><b>Advantages: ( any four)</b></p> <p>These give more accurate results.</p> <p>Bourdon tube cost low.</p> <p>Bourdon tube are simple in construction.</p> <p>They can be modified to give electrical outputs.</p> <p>They are safe even for high pressure measurement.</p> <p>Accuracy is high especially at high pressures.</p> | <p><b>02 Marks for dia.</b></p> <p><b>1/2 Marks for any 4 adv.</b></p> |
| b)  | A circular plate 3.5 m diameter is fully immersed in water at an angle of 45° with the vertical. Determine the total pressure and the centre of pressure on the plate when its centre is 3 m below the free surface of water.  |  |
| Ans | $d = 3.5 \text{ m}$ $\theta = 45^\circ$ $\bar{x} = 3 \text{ m}$ $I_G = \frac{\pi}{64} d^4$ $= \frac{\pi}{64} \times 3.5^4$ $\therefore I_G = 7.366 \text{ m}^4$ $\text{Area of circular plate} = \frac{\pi}{4} d^2$ $= \frac{\pi}{4} \times (3.5)^2$ $\therefore a = 9.62 \text{ m}^2$   | <p>01 Mark</p> <p>01 Mark</p>  |



$$\text{Total Pressure} = W \cdot A \cdot \bar{x}$$

$$= 9810 \times 9.62 \times 3$$

$$= 283149.78 \text{ N}$$

$$\therefore \text{Total Pressure} = \underline{\underline{283.149 \text{ kN}}}$$

$$\text{Centre of pressure} = \frac{I_G}{A \bar{x}} \cdot \sin^2 \theta + \bar{x}$$

$$= \frac{7.366}{9.62 \times 3} \times \sin^2 45 + 3$$

$$\therefore \text{Centre of pressure} = \underline{\underline{3.1276 \text{ m}}}$$

01 Mark

01 Mark

c)

**Explain Bernoulli's theorem with neat sketch. State its two important assumptions.**

**Ans**

This theorem states that whenever there is continuous flow of liquid the total energy at every section remains same provided that there is no any addition or loss of energy.

$$P/W + V^2/2g + Z = \text{constant}$$

Where,  $P/W$  = Pressure energy

$V^2/2g$  = Kinetic energy

$Z$  = Potential energy

Let us consider a conduit having 2-sections.

Now, **By using Bernoulli's Theorem,**

Total head at section 1 = Total head at section 2

$$P_1/W + V_1^2/2g + Z_1 = P_2/W + V_2^2/2g + Z_2$$

01 Mark  
for  
statement

01 Mark

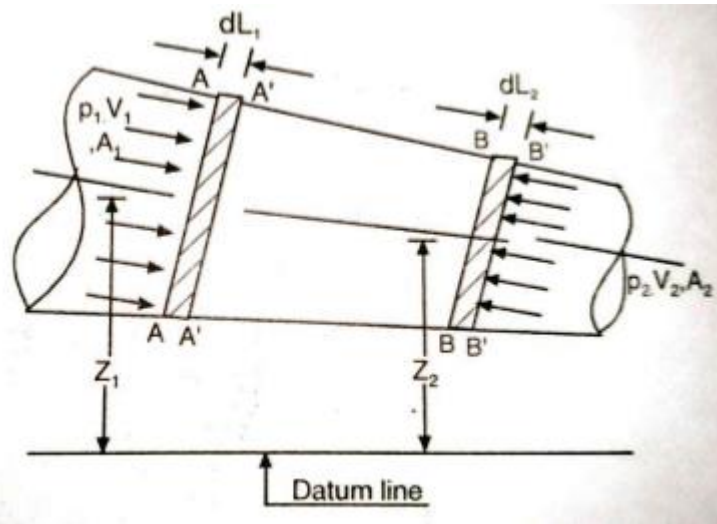

**Assumptions: (any two)**

1. The fluid is ideal.
2. The flow is steady & continuous.
3. The flow is incompressible.
4. Velocity is uniform over the cross section.
5. The flow is irrotational.

01 Mark  
for sketch

01 Mark

**d) Compare i) Steady and uniform flow  
ii) Laminar and turbulent flow ( Two important points)**

**Ans**

**Steady flow:-** The flow is said to be steady when the flow characteristics, such as velocity, pressure, density and temperature do not change with time.

Water flowing through a tap at a constant rate is an example of steady flow.

**Uniform flow:-** The flow in which velocity at a given time does not change with respect to space (length of direction of flow) is called as uniform flow.

This term is generally applied to flow in channels.

**Laminar flow:-** The flow in which each liquid particle has definite path and path of individual particles do not cross each other is called as laminar flow.

e.g. Movement of blood in human body, the flow of thick oil through a small tube.

**Turbulent flow:-** Flow in which each liquid particle does not have a definite path and the path of individual particles also cross each other is called as turbulent flow.

e.g. The flow of river at the time of flood is turbulent flow.

01 Mark

01 Mark

01 Mark

01 Mark



- b) Sudden contraction of pipe
- c) Pipe fittings
- d) Bend in pipe
- e) Loss of head at Entry.
- f) Loss of head at Exit.

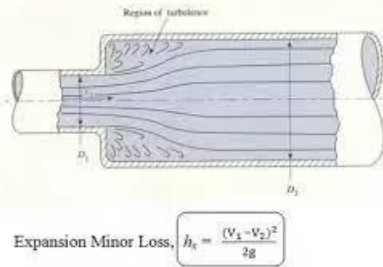

When  $V_1, V_2$  are velocities on the two sides or the section at which sudden enlargement occurs. The head loss resulting from pipe expansion may be greatly reduced by introducing gradual pipe transition known as diffuser.

02 Marks

**d)** Draw velocity diagram for symmetrical and moving curved vane when jet strikes at one end with certain velocity at certain angle and meaning the vane from other end. State the meaning of terminologies used in the diagram.

**Ans:** **velocity diagram for symmetrical and moving curved vane:**

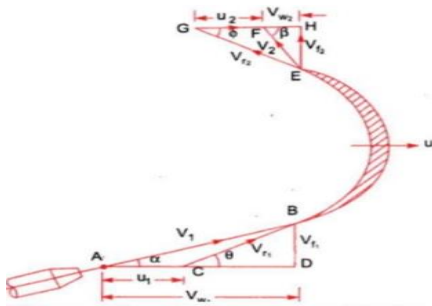

- $V_1$  = Velocity of the jet (AB), while entering the vane,
- $V_2$  = Velocity of the jet (EF), while leaving the vane,
- $u_1, u_2$  = Velocity of the curved vane at inlet & outlet (AC, FG)
- $\alpha$  = Angle with the direction of motion of the vane, at which the jet enters the vane,
- $\beta$  = Angle with the direction of motion of the vane, at which the jet leaves the vane,
- $V_{r1}$  = Relative velocity of the jet and the vane (BC) at entrance (it is the vertical difference between  $V_1$  and  $u_1$ )
- $V_{r2}$  = Relative velocity of the jet and the vane (EG) at exit (it is the vertical difference between  $V_2$  and  $u_2$ )
- $\Theta$  = Angle, which  $V_{r1}$  makes with the direction of motion of the vane at inlet (known as vane angle at inlet),
- $\beta$  = Angle, which  $V_{r2}$  makes with the direction of motion of the vane at outlet (known as vane angle at outlet),
- $V_{w1}$  = Horizontal component of  $V_1$  (AD, equal to). It is a component parallel to the direction of motion of the vane (known as velocity of whirl at inlet),
- $V_{w2}$  = Horizontal component of  $V_2$  (FH, equal to). It is a component parallel to the direction of motion of the vane (known as velocity of whirl at outlet),
- $V_{f1}$  = Vertical component of  $V_1$  (BD, equal to). It is a component at right angles to the direction of motion of the vane (known as velocity of flow at inlet),

02 Marks

02 Marks

|   |             |  |                               |
|---|-------------|--|-------------------------------|
|   |             | <p>• <math>V_{f2}</math> = Vertical component of <math>V_2</math> (EH, equal to ). It is a component at right angles to the direction of motion of the vane (known as velocity of flow at outlet)</p>  |                               |
|   | e)          | <p>A jet of water of diameter 30 mm moving with velocity of 35 m/s ,strikes a curved symmetrical plate at the center Find the force exerted by jet of water in direction of jet. If jet is deflected through an angles of <math>150^\circ</math> at outlet of curved plate. If the vane is moving with the velocity of 20 m/s in the direction of jet .Find out the force exerted .</p>  |                               |
|   | <b>Ans:</b> | <p>Velocity of jet <math>V = 35</math> m/s<br/>           Velocity of vane <math>u = 20</math> m/s<br/>           The value of <math>\theta</math> i.e. angle made by tip of vane at outlet as<br/> <math>\Theta = 180 - \text{angle of deflection} = 180 - 150 = 30^\circ</math><br/>           Calculate : Force exerted ny jet<br/>           diameter of nozzle as 30 mm <math>a = \pi/4 \times d^2 = \pi/4 \times 0.03^2 = 7.07 \times 10^{-4}</math><br/>           Force exerted by the jet on vane<br/> <math>F_x = \rho a (v - u)^2 (1 + \cos\theta)</math><br/> <math>F_x = 1000 \times 7.07 \times 10^{-4} (35 - 20)^2 (1 + \cos 30) = 296.83</math> N<br/>           Force exerted by the jet on vane = 296.83 N</p> | <p>2 Marks</p> <p>2 Marks</p> |
| 4 |             | Attempt any THREE of the following   |                               |
|   | a)          | Draw the layout of hydroelectric power plant and classify the turbines used in it.   |                               |
|   |             | <p>Layout of hydroelectric power plant:</p> <p style="text-align: center;"><i>Layout of a hydro-eletric power plant.</i></p>   | 2 Marks                       |
|   |             | <p><b>Classification of the hydraulic turbines:</b></p> <p>According to the type of energy available at inlet to the turbine<br/>           1) impulse turbine and 2) Reaction turbine<br/>           According to direction of flow through runner<br/>           1) tangential flow turbine 2) radial flow turbine 3) axial flow turbine 4) mixed flow turbine<br/>           According to the head available at inlet to the turbine</p>  | 2 Marks                       |



|  |             |  |         |
|--|-------------|--|---------|
|  |             | <p>1) Low head turbine (2 m to 15 m) 2)Medium head turbine (16 m to 70 m) 3)High head turbine (71 m and above)<br/>According to the specific speed of the turbine<br/>1)low specific speed 2)medium specific speed 3)High specific speed</p>   |         |
|  | <b>b)</b>   | <b>Explain the Need of draft tube in reaction turbine .state the types of draft tube used in it</b>  |         |
|  | <b>Ans:</b> | <p>Draft tube is a pipe of gradually increasing diameter which connects the exit of runner of turbine to tail race. In case of reaction turbine , one part of available head is converted into K.E before entry to runner and rest of energy is in the form of pressure energy. This pressure energy is gradually converted into runner, thus the velocity leaving the runner is at high velocity.<br/>Draft converts K.E to pressure head . also<br/>1) To decrease the pressure at the runner exit to a value less than atmospheric pressure and thereby increase the effective working head.<br/>ii) To recover a part of electric energy into pressure head at the exit of draft tube. This enables easy discharge to atmosphere.</p> <p><b>Types of draft tube:</b><br/>i. Conical draft tube.<br/>ii. Simple elbow draft tube.<br/>iii. Moody spreading draft tube.<br/>iv. Elbow draft tube with circular cross section at inlet and rectangular at outlet.</p> | 2 Marks |
|  |             |  | 2 Marks |
|  | <b>c)</b>   | <b>Draw and explain performance and operating characteristics curves of a Pelton turbine</b>   |         |
|  | <b>Ans:</b> | <p>The followings are the important <b>characteristic curves</b> of a <b>turbine</b> : Main <b>Characteristic Curves</b> or Constant Head <b>Curve</b>. ... The speed of the <b>turbine</b> is varied by changing load on the <b>turbine</b>. For each value of the speed, the corresponding values of the power (P) and discharge (Q) are obtained.</p>   | 2 Marks |

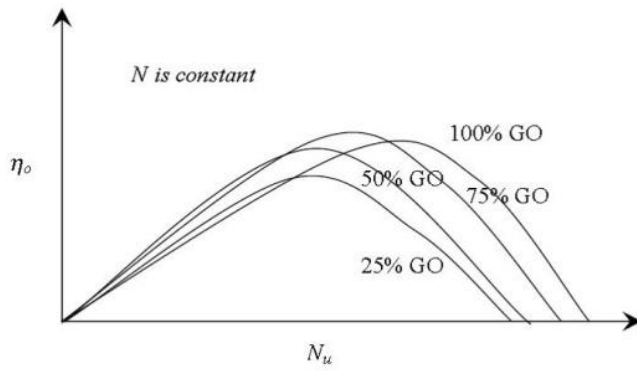

2 Marks

**OPERATING CHARACTERISTIC CURVES / Const. Speed curves** • Tests are performed at constant speed. • Const. speed is attained by regulating the gate opening thereby varying the discharge flowing through the turbine as the load varies. • Head may or may not kept constant.

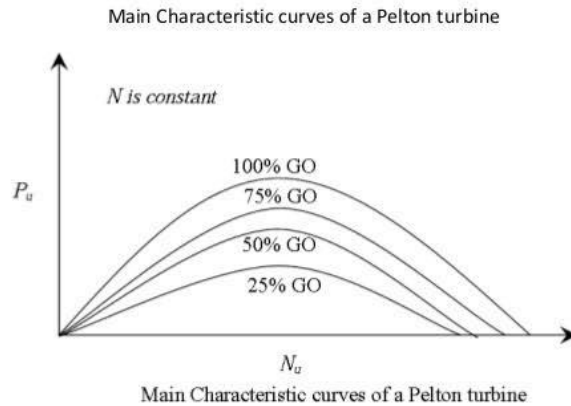

**d)** State any four faults in centrifugal pump and their remedies

| <b>Ans:</b> | Sr.No | Fault                                    | remedies  |
|-------------|-------|--|---|
|             | 1     | Pump fails to start pumping              | Reprime the pump , Clean the impeller<br>Reduce suction lift , Increase the speed                                 |
|             | 2     | Pump stops working                       | Remove air by priming<br>Reduces suction lift   |
|             | 3     | Pump is not lifting water up to capacity | Plug leakage<br>Replace the damaged or worn out parts   |
|             | 4     | Pump has very low efficiency             | Reduce the speed<br>Correct the direction of rotation of impeller<br>Reduce the discharge , Repair affected parts |

4 Marks

**f)** Discuss the factors considered for selection of pump

**Ans:** 1) Pressure: Pump is used to pressurize the fluid in system according to need of pressure we can select pump as below



|                    |   |   |               |                          |                    |     |                    |     |                 |     |                    |     |            |     |                   |   |                                       |
|--------------------|---|---|---------------|--------------------------|--------------------|-----|--------------------|-----|-----------------|-----|--------------------|-----|------------|-----|-------------------|---|---------------------------------------|
|                    |   | <table border="1" style="width: 100%; border-collapse: collapse;"> <tr> <td style="width: 35%;">Types of pump</td> <td style="width: 65%;">Pressure range ( In bar)</td> </tr> <tr> <td>External gear pump</td> <td>300</td> </tr> <tr> <td>Internal gear pump</td> <td>350</td> </tr> <tr> <td>Fixed vane pump</td> <td>175</td> </tr> <tr> <td>Variable vane pump</td> <td>125</td> </tr> <tr> <td>Screw pump</td> <td>175</td> </tr> <tr> <td>Axial piston type</td> <td>700                  More than 500 bar)</td> </tr> </table> <p>2) Speed of pump: if the speed of pump is increased beyond its rated speed then problems like cavitations takes place. This problem directly affect on efficiency &amp; working of hydraulic system.</p> <p>3) Flow of pressurized oil: Vol. of oil at output is measured in litre per min have flow of oil deciding speed of actuators</p> <p>4) Efficiency of pump:<br/>Selection of pump depends on required efficiency like volumetric efficiency , mechanical efficiency, overall efficiency</p> <p>5) Oil compatibility:<br/>The meaning of compatibility is nothing but acceptance .each pump is compatible to hy.oil but if used different oil, then pump will not give a good performance.</p> <p>6) cost of pump:<br/>There are different varieties o pumps available in market according to application we can choose it by economical aspect cost of pump &amp; its spares should be less.</p> | Types of pump | Pressure range ( In bar) | External gear pump | 300 | Internal gear pump | 350 | Fixed vane pump | 175 | Variable vane pump | 125 | Screw pump | 175 | Axial piston type | 700                  More than 500 bar) | <p>4 Marks</p> <p>Any four points</p> |
| Types of pump      | Pressure range ( In bar)                |   |               |                          |                    |     |                    |     |                 |     |                    |     |            |     |                   |   |                                       |
| External gear pump | 300                                     |   |               |                          |                    |     |                    |     |                 |     |                    |     |            |     |                   |   |                                       |
| Internal gear pump | 350                                     |   |               |                          |                    |     |                    |     |                 |     |                    |     |            |     |                   |   |                                       |
| Fixed vane pump    | 175                                     |   |               |                          |                    |     |                    |     |                 |     |                    |     |            |     |                   |   |                                       |
| Variable vane pump | 125                                     |   |               |                          |                    |     |                    |     |                 |     |                    |     |            |     |                   |   |                                       |
| Screw pump         | 175                                     |   |               |                          |                    |     |                    |     |                 |     |                    |     |            |     |                   |   |                                       |
| Axial piston type  | 700                  More than 500 bar) |   |               |                          |                    |     |                    |     |                 |     |                    |     |            |     |                   |   |                                       |
| 5                  |   | <b>Attempt any TWO of the following:</b>  | 12            |                          |                    |     |                    |     |                 |     |                    |     |            |     |                   |   |                                       |
|                    | <b>a)</b>                               | Derive equation for discharge through orifice meter with the help of neat sketch.   |               |                          |                    |     |                    |     |                 |     |                    |     |            |     |                   |   |                                       |
|                    | <b>Ans:</b>                             | <p><b>Orifice Meter or orifice Plate:</b> It is a device used for measuring the rate of flow of a fluid through a pipe. It is Cheaper device as compared to venturimeter. It also works on the same principle as that of venturimeter. It consist of flat circular plate which has a cirxular sharp edged hole called orifice, which is concentric with the pipe. The orifice diameter is kept generally 0.5 times the diameter of the pipe, though it may vry from 0.4 to 0.8 times the pipe diameter.</p> <p>A differential manometer is connected at section (1) , which is at a distance of about 1.5 to 2.0 times the pipe diameter upstream from the orifice plate, and at section (2), which is at a distance of about half the diameter of the orifice on the downstream side from the orifice plate.</p>   |               |                          |                    |     |                    |     |                 |     |                    |     |            |     |                   |   |                                       |

Let  $p_1$  = pressure at section (1),  
 $v_1$  = velocity at section (1),  
 $a_1$  = area of pipe at section (1), and

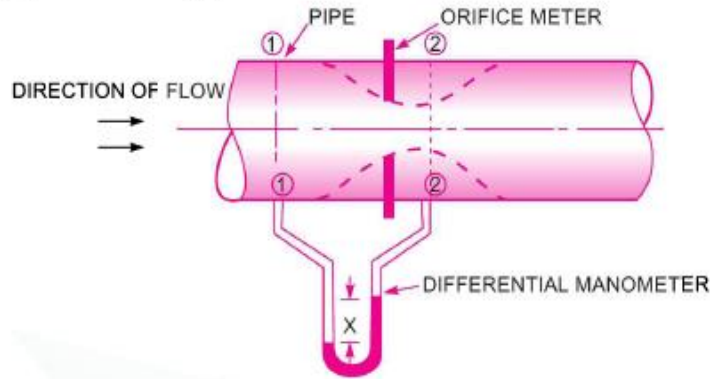

2 Marks

$p_2, v_2, a_2$  are corresponding values at section (2). Applying Bernoulli's equation at sections (1) and (2), we get

$$\frac{p_1}{\rho g} + \frac{v_1^2}{2g} + z_1 = \frac{p_2}{\rho g} + \frac{v_2^2}{2g} + z_2$$

or 
$$\left( \frac{p_1}{\rho g} + z_1 \right) - \left( \frac{p_2}{\rho g} + z_2 \right) = \frac{v_2^2}{2g} - \frac{v_1^2}{2g}$$

But 
$$\left( \frac{p_1}{\rho g} + z_1 \right) - \left( \frac{p_2}{\rho g} + z_2 \right) = h = \text{Differential head}$$

$$\therefore h = \frac{v_2^2}{2g} - \frac{v_1^2}{2g} \quad \text{or} \quad 2gh = v_2^2 - v_1^2$$

or 
$$v_2 = \sqrt{2gh + v_1^2} \quad \dots(i)$$

Now section (2) is at the vena-contracta and  $a_2$  represents the area at the vena-contracta. If  $a_0$  is the area of orifice then, we have

$$C_c = \frac{a_2}{a_0}$$

where  $C_c$  = Co-efficient of contraction

$$\therefore a_2 = a_0 \times C_c \quad \dots(ii)$$

By continuity equation, we have

$$a_1 v_1 = a_2 v_2 \quad \text{or} \quad v_1 = \frac{a_2}{a_1} v_2 = \frac{a_0 C_c}{a_1} v_2 \quad \dots(iii)$$

Substituting the value of  $v_1$  in equation (i), we get

$$v_2 = \sqrt{2gh + \frac{a_0^2 C_c^2 v_2^2}{a_1^2}}$$

2 Marks



|      |   |         |
|------|---|---------|
|      | <p>or <math display="block">v_2^2 = 2gh + \left(\frac{a_0}{a_1}\right)^2 C_c^2 v_2^2 \text{ or } v_2^2 \left[1 - \left(\frac{a_0}{a_1}\right)^2 C_c^2\right] = 2gh</math></p> <p><math>\therefore v_2 = \frac{\sqrt{2gh}}{\sqrt{1 - \left(\frac{a_0}{a_1}\right)^2 C_c^2}}</math></p> <p><math>\therefore</math> The discharge <math>Q = v_2 \times a_2 = v_2 \times a_0 C_c</math> <span style="float: right;">{ <math>\because a_2 = a_0 C_c</math> from (ii) }</span></p> $= \frac{a_0 C_c \sqrt{2gh}}{\sqrt{1 - \left(\frac{a_0}{a_1}\right)^2 C_c^2}} \quad \dots(iv)$ <p>The above expression is simplified by using</p> $C_d = C_c \frac{\sqrt{1 - \left(\frac{a_0}{a_1}\right)^2}}{\sqrt{1 - \left(\frac{a_0}{a_1}\right)^2 C_c^2}}$ <p><math>\therefore C_c = C_d \frac{\sqrt{1 - \left(\frac{a_0}{a_1}\right)^2 C_c^2}}{\sqrt{1 - \left(\frac{a_0}{a_1}\right)^2}}</math></p> <p>Substituting this value of <math>C_c</math> in equation (iv), we get</p> $Q = a_0 \times C_d \frac{\sqrt{1 - \left(\frac{a_0}{a_1}\right)^2 C_c^2}}{\sqrt{1 - \left(\frac{a_0}{a_1}\right)^2}} \times \frac{\sqrt{2gh}}{\sqrt{1 - \left(\frac{a_0}{a_1}\right)^2 C_c^2}}$ $\approx \frac{C_d a_0 \sqrt{2gh}}{\sqrt{1 - \left(\frac{a_0}{a_1}\right)^2}} = \frac{C_d a_0 a_1 \sqrt{2gh}}{\sqrt{a_1^2 - a_0^2}}$ | 2 Marks |
| b)   | <p>A pipe line 2000m long carries water having pressure of 50 bar at inlet. The pressure drop over the length of pipe is 1000 kN/m<sup>2</sup>. If the power transmitted through pipe is 110kW and coefficient of friction is 0.0055 Find 1) Diameter of pipe 2) Efficiency of transmission</p>   |         |
| Ans: | <p>Given:</p> <p><math>L = 2000 \text{ m}, \quad P = 50 \text{ bar} = 50 \times 10^5 \text{ N/m}^2</math></p> <p><math>dP = 1000 \text{ kN/m}^2 \quad P = 110 \text{ kW},</math></p> <p><math>f = 0.0055</math></p> <p>1) Diameter of pipe</p> <p>Pressure head at inlet <math>H = P/\rho g = 50 \times 10^5 / (1000 \times 9.81) = 509.7 \text{ m}</math></p>  |         |



|      |  |   |
|------|--|---|
|      | <p><i>Loss of head</i> <math>h_f = d P / \rho g = 1000 \times 10^3 / (1000 \times 9.81) = 101.94 \quad \text{m}</math></p> <p><math>h_f = f L V^2 / 2 g d</math></p> <p><math>101.94 = 0.0055 \times 1000 \times v^2 / (2 \times 9.81 \times d)</math></p> <p><math>v = 19.06 d^{1/2}</math></p> <p>Head available at the end of pipe = <math>H - h_f</math></p> <p>Power transmitted through pipe <math>P = \rho g Q (H - h_f) / 1000 \quad \text{kW}</math></p> <p><math>110 \times 10^3 = 1000 \times 9.81 \times (\pi/4) \times d^2 \times v \times (509.7 - 101.94)</math></p> <p><math>110 \times 10^3 = 1000 \times 9.81 \times (\pi/4) \times d^2 \times d^{1/2} \times (509.7 - 101.94)</math></p> <p><math>d^{3/2} = 0.035</math></p> <p><math>d = 0.1069 \text{ m}</math></p> <p>2) Efficiency of power Transmission</p> <p><math>\eta = (H - h_f) / H = (509.7 - 101.94) / 509.7 = 0.8 = 80\%</math></p>   | <p>2 Marks</p> <p>2 Marks</p> <p>2 Marks</p>                |
| c)   | <p>A jet moving with a velocity of <math>V \text{ m/s}</math> is made to strike a stationary i) flat plate normally ii) flat inclined at an angle <math>\theta</math> iii) symmetrical curved vane at centre with tip angle <math>\theta</math></p> <p>In which case the force exerted by the jet is maximum?</p> <p>Justify with suitable sketch and formula.</p>   |   |
| Ans: | <p>i) Force exerted by jet on flat plate normally <math>= \rho A V^2</math></p> <p>ii) Force exerted by jet on flat plate inclined at an angle <math>\theta = \rho A V^2 \sin \theta</math></p> <p>iii) Force Exerted by jet on symmetrical curved vane at centre with tip angle <math>\theta</math></p> <p><math>F = \rho A V^2 (1 + \cos \theta)</math></p> <p>Force exerted by jet on symmetrical curved vane at centre with tip angle <math>\theta</math> is maximum.</p> <p><b>Justification:</b></p> <ul style="list-style-type: none"> <li>Force exerted by jet on symmetrical curved vane at centre with tip angle <math>\theta</math> is maximum.</li> <li>Because it contains <math>(1 + \cos \theta)</math> term and as <math>\theta</math> varies between <math>0</math> to <math>90^\circ</math> <math>\cos \theta</math> is positive and <math>(1 + \cos \theta)</math> is always greater than 1.</li> <li>Hence Force exerted by jet on symmetrical curved vane at centre with tip angle <math>\theta</math> is maximum.</li> </ul> | <p>1 Marks</p> <p>1 Marks</p> <p>2 Marks</p> <p>2 Marks</p> |
| 6    | <p><b>Attempt any TWO of the following:</b></p>  | 12  |
| a)   | <p><b>Explain Construction and working of Francis Turbine with neat sketch.</b></p>  |   |

|             |   |         |
|-------------|---|---------|
| <b>Ans:</b> | <p>The main parts of the Francis turbine are:</p> <ol style="list-style-type: none"> <li>1) Penstock: It is the large pipe which conveys water from the upstream of the reservoir to the turbine runner.</li> <li>2) Spiral casing: It is a closed passage whose cross sectional area gradually decreases along the flow direction. Area is maximum at the inlet and nearly zero at the outlet.</li> <li>3) Guide vanes: These vanes direct the water onto the runner at an angle appropriate to the design.</li> <li>4) Runner and runner blades: The driving force on the runner is both due to impulse and reaction effect. The number of a runner blade usually varies between 16 to 24.</li> <li>5) Draft tube: It is gradually expanding tube which discharges the water passing through the runner to the tail race.</li> </ol> <p>Working</p> <ol style="list-style-type: none"> <li>1) It is inward mixed flow reaction turbine i.e. Water under the pressure enters the runner from the guide vanes towards the centre in the radial direction and discharge out axially.</li> <li>2) It operates under the medium head and medium discharge.</li> <li>3) water is brought down to the turbine through the penstock and directed to the guide vanes which direct the water onto the runner at an angle appropriate to the design.</li> <li>4) In the Francis turbine runner is always full of water.</li> </ol> <p>After doing the work the water is discharge to the trail race through the draft tubes.</p> | 2 Marks |
|             |   | 2 Marks |
| <b>b)</b>   | <p><b>Ans:</b></p> <p>Given:</p> <p><math>H_m = \text{Manometric head} = 14.5\text{m}</math></p> <p><math>N = 1000\text{rpm}</math> , <math>\Phi = \text{Vane angle at outlet} = 30^\circ</math></p> <p><math>D_2 = \text{Diameter at outlet} = 300\text{mm} = 0.3\text{m}</math></p> <p><math>B_2 = \text{Width at the outlet} = 50\text{mm} = 0.05\text{m}</math> &amp; <math>\eta_{\text{mano}} = 0.95</math> &amp; <math>\eta_{\text{over}} = 0.90</math></p>   |         |

To find: 1) Discharge. 2) Power required to the drive the pump.

Solution:

1) Discharge (Q)

Velocity Triangle

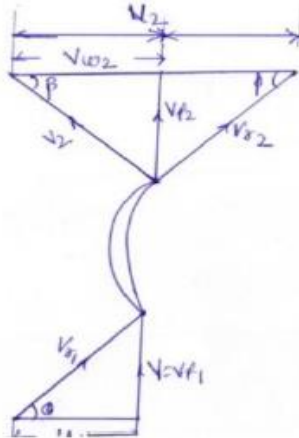

$$\tan 30 = (V_{f2}/u_2 - V_{w2})$$

$$\eta_{\text{mano}} = (gH_m / u_2 V_{w2})$$

$$\text{Also } u_2 = (\pi D_2 N) / (60) = (\pi \times 0.3 \times 1000) / (60) = 15.71 \text{ m/s}$$

$$0.95 = (9.81 \times 14.5 / 15.71 \times V_{w2})$$

$$V_{w2} = 9.53 \text{ m/s}$$

$$\tan 30 = (V_{f2} / 15.71 - 9.53)$$

$$\tan 30 = (V_{f2} / 6.18)$$

$$V_{f2} = 6.18 \times \tan 30 = 3.57 \text{ m/s}$$

$$\text{Discharge (Q)} = \pi D_2 B_2 V_{f2}$$

$$Q = \pi \times 0.3 \times 0.05 \times 3.57 = 0.1682 \text{ m}^3/\text{s}$$

2) Power required to the drive the pump

$$\eta_{\text{overall}} = wQH_m / \text{Input Power}$$

$$\text{Input Power} = \rho QH_m / \eta_{\text{overall}} = 1000 \times 9.81 \times 0.1682 \times 14.5 / 0.9$$

$$\text{Input Power} = 26.58 \text{ kW}$$

2 Marks

2 Marks

2 Marks

c)

**Ans:**

Given:  $N = 50 \text{ rpm}$ ,  $Q = 0.00736 \text{ m}^3/\text{s}$   $D = 300 \text{ mm}$ ,

$L = 300 \text{ mm}$   $H_s = 3.5 \text{ m}$   $H_d = 11.5 \text{ m}$ ,

Determine : 1) Theoretical Discharge 2) Slip 3) Power required to run the pump





Solution:

1) Theoretical Discharge

$$Q_{th} = \frac{A \cdot L \cdot N}{60}$$

$$= \left(\frac{\pi}{4}\right) \times D^2 \times L \cdot N / 60$$

$$= \left(\frac{\pi}{4}\right) \times 0.3^2 \times 0.3 \times 50 / 60$$

$$= 0.0176 \text{ m}^3/\text{s}$$

2 Marks

2) Slip =  $Q_{th} - Q_{act} = 0.021 - 0.0176 = 0.0034 \text{ m}^3/\text{s}$

2 Marks

3) Power required to run the pump

$$P = \frac{\rho \cdot g \cdot A \cdot L \cdot N \cdot (H_s + H_d)}{60000} \text{ kW}$$

2 Marks

$$P = 1000 \times 9.81 \times \left(\frac{\pi}{4}\right) \times 0.3^2 \times 0.3 \times 50 \times (3.5 + 11.5) / 60000$$

$$P = 2.6 \text{ kW}$$